

MARQUIS 38

DVT-38 & DVR-38

DIRECT VENT GAS FIREPLACE

FOR USE WITH NATURAL GAS OR PROPANE*

WARNING: If the information in this manual is not followed exactly, fire or explosion may result causing property damage, personal injury or loss of life.

Do not store or use gasoline or other flammable vapors and liquids in the vicinity of this or any other appliance.

WHAT TO DO IF YOU SMELL GAS:

- * Do not try to light any appliance.
- * Do not touch any electrical switch; do not use any phone in your building.
- * Immediately call your gas supplier from a neighbor's phone. Follow the gas supplier's instructions.
- * If you cannot reach your gas supplier, call the fire department.

Installation and service must be performed by a qualified installer, service agency or the gas supplier.

USERS' INSTALLATION OPERATION AND MAINTENANCE MANUAL

This appliance may be installed in an after-market, permanently located, manufactured home (USA only) or mobile home, where not prohibited by local codes.

This appliance is only for use with the type of gas indicated on the rating plate. This appliance is not convertible for use with other gases, unless a certified kit is used.

*Conversion Kit Required for Propane Use

Installer: Please leave this manual with the appliance owner for future reference

CONTENTS

	Page
Introduction	4
General Information	5
Appliance Description and Dimensions	6
Framing Dimensions	7
Clearance to Combustibles	8
Possible Fireplace Locations	9
Venting Instructions	10 - 13
Gas Connections	14
Glass Door Instructions	15
Log Placement Instructions	16
Fan and Valve Diagrams	17
Initial Start Up	18 - 19
Maintenance	20
Troubleshooting	21 - 22
Servicing	23 - 26
Replacement Parts List	27
Warranty	28
Warranty Registration	29

Manufactured by Archgard Industries Ltd., British Columbia, Canada.

Patents Pending

INTRODUCTION

Thank you for purchasing the Marquis DV-38 Direct Vent Built-in Gas Fireplace.

The Marquis DV-38 is one of the most advanced gas fireplaces on the market. It is designed using the latest technology and manufactured to the highest quality.

Some of the many features are:

- * **Realistic Fire** The Marquis DV-38 has a glowing ember bed in front and soft flowing flames at the back. A realistic split log set complements the flames.
- * **Solid Construction** The Marquis DV-38 is constructed mainly of satin coated and galvanized steel for long life and durability.

Please read the manual carefully prior to installation and operation of the appliance. Proper installation, operation and maintenance of the appliance will provide you with many years of enjoyment.

CAUTION

Due to high temperatures, the appliance should be located out of traffic and away from furniture and draperies.

Children and adults should be alerted to the hazards of high surface temperature and stay away to avoid burns or clothing ignition.

Young children should be carefully supervised when they are in the same room as the appliance.

Clothing or other flammable material should not be placed on or near the appliance.

Do not operate with cracked or broken glass. Be careful not to strike or slam the glass.

Any safety screen or guard removed for servicing an appliance must be replaced prior to operating.

Installation and Repair should be done by a qualified service person. The appliance should be inspected before use and at least annually by a professional service person. More frequent cleaning may be required due to excessive lint from carpeting, bedding materials, et cetera. It is imperative that the control compartments, burners and circulating air passageways of the appliance are kept clean.

GENERAL INFORMATION

APPLIANCE CERTIFICATION

This appliance is listed by Warnock Hersey for use in both the United States and Canada. It is tested and certified to the following US and Canadian gas appliance standards.

- ANSI Z21.50-1996 / CGA 2.22-M96, Vented Gas Fireplace and Heaters
- CAN/CGA-2.17-M91, Gas-Fired Appliances for Use at High Altitudes.

Please contact Archgard Industries Ltd. if you have any questions regarding the certification of this appliance.

INSTALLATION CODES

This appliance must be installed by a qualified gas appliance installer.

The installation must conform with the local codes or, in the absence of local codes, with the current National Fuel Gas Code, ANSI Z223.1/ NFPA 54, in the US or Installation Code, CAN/CGA-B149, in Canada.

Electrical connections and grounding must conform with local code, or current National Electrical code, ANSI/NFPA No. 70-1987, in the US and in Canada, the current Canadian Electrical Code, CSA C22.1.

SPECIFICATIONS

	Natural Gas (NG)	Propane (LP)
Manifold Pressure	3.5 in. w.c. (0.9 kPa)	10.0 in. w.c. (2.5 kPa)
Min. Supply Pressure for Purpose of Input Adjustment	4.5 in. w.c. (1.2 kPa)	11.0 in. w.c. (2.8 kPa)
Orifice Size	#48 DMS (1.93 mm dia.)	#56 DMS (1.18 mm dia.)
Nominal Input Rating	16,000 BTU/hr (4.6 kW)	16,000 BTU/hr (4.6 kW)
Altitude	0 - 4,500 ft. (0 - 1372 m)	0 - 4,500 ft. (0 - 1372 m)
Primary Air Opening	¼ in. (6 mm)	½ in. (13 mm)

HIGH ALTITUDE INSTALLATION

When installing this appliance beyond 4500 ft. (1372 m) above sea level, the appliance must be properly de-rated and installed according to local codes. In the absence of local codes, with the current National Fuel Gas Code, ANSI Z223.1/ NFPA 54, in the US or Installation Code, CAN/CGA-B149, in Canada.

APPLIANCE DESCRIPTION & DIMENSIONS

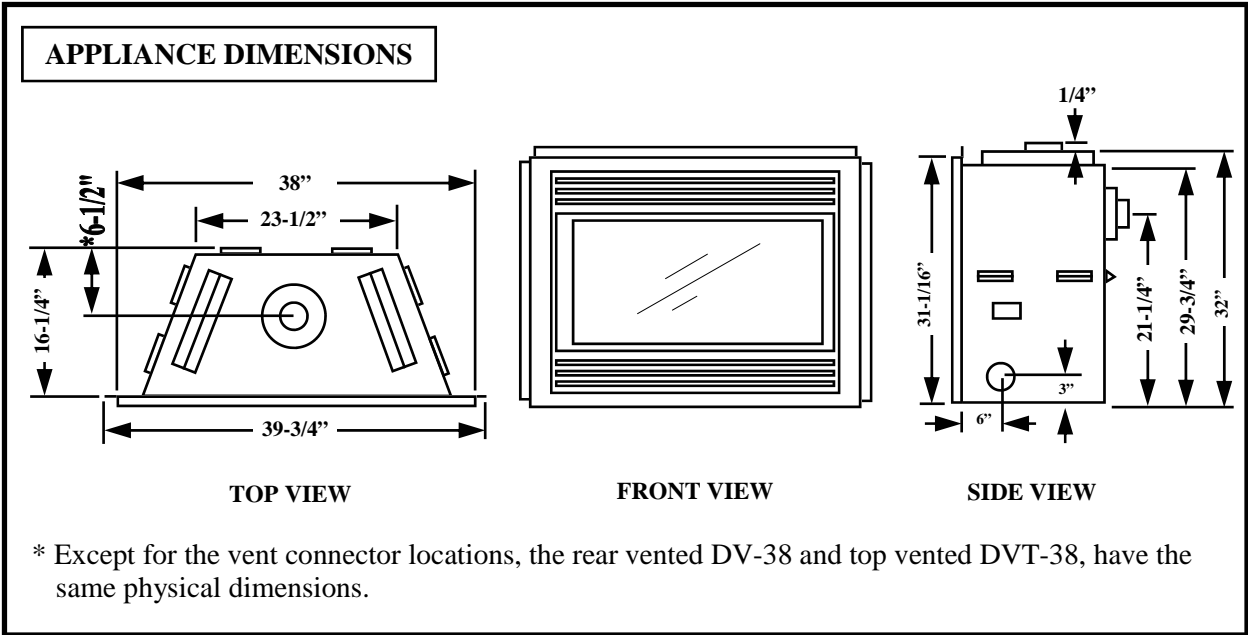
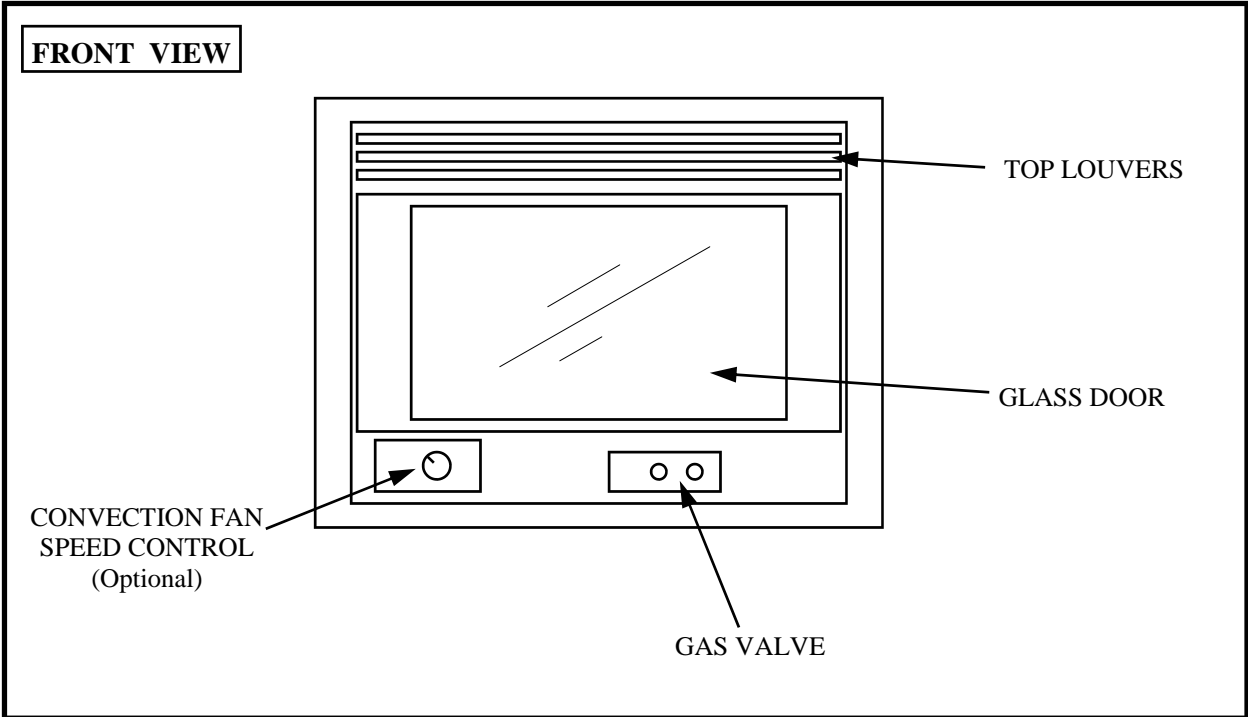

FRAMING DIMENSIONS

FRAMING DIMENSIONS

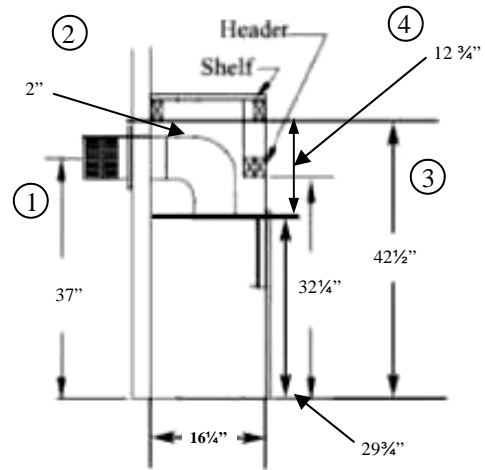
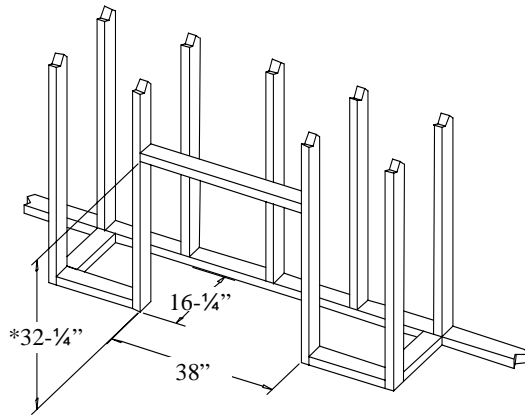

WHEN INSTALLING A SHELF OVER THE TOP OF REAR / TOP VENT MODEL DV38, THE FOLLOWING APPLIES:

1. Minimum height from floor to center of top vent must be 37" (940mm)
2. Minimum height from top of vent to combustible material is 2" (51mm)
3. Minimum height from floor to combustible materials used for frame / shelf is 42 1/2" (1080mm)
4. Minimum height from top of unit (not stand-offs) to combustible material for frame / shelf is 12 3/4" (324mm)

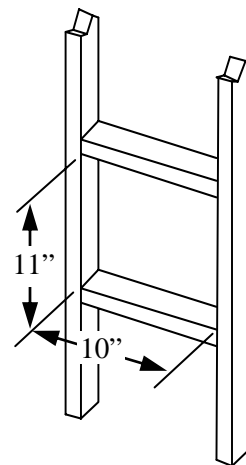
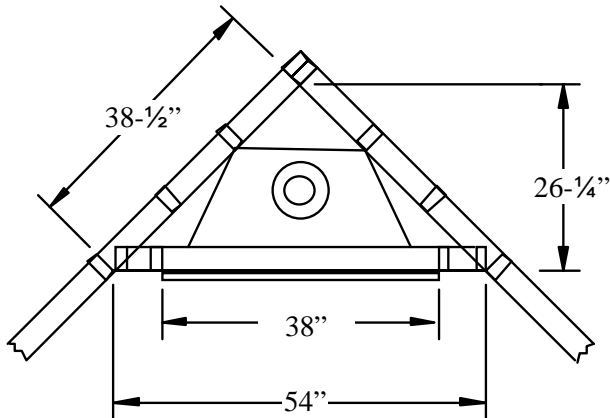
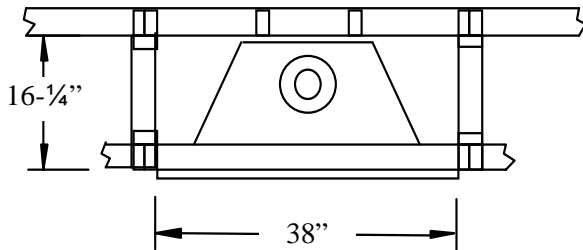

TERMINATION FRAMING

CLEARANCE TO COMBUSTIBLES

PRECAUTIONS

- This appliance must be installed by a qualified gas installer and the installation must conform to the installation codes.
- Provide adequate clearance around air openings of the appliance. Never obstruct front openings.
- Provide adequate clearances for proper operation and servicing of the appliance.
- This appliance must be properly connected to a venting system.

CLEARANCES TO COMBUSTIBLES

BACK	0" to stand-offs
SIDES	0" to stand-offs
TOP	0" to stand-offs
BOTTOM	0"
ADJACENT SIDE WALL	1" to side of faceplate
MANTLE	see diagram
VENT	1" to outside side and bottom surface, 2" to outside top surface.

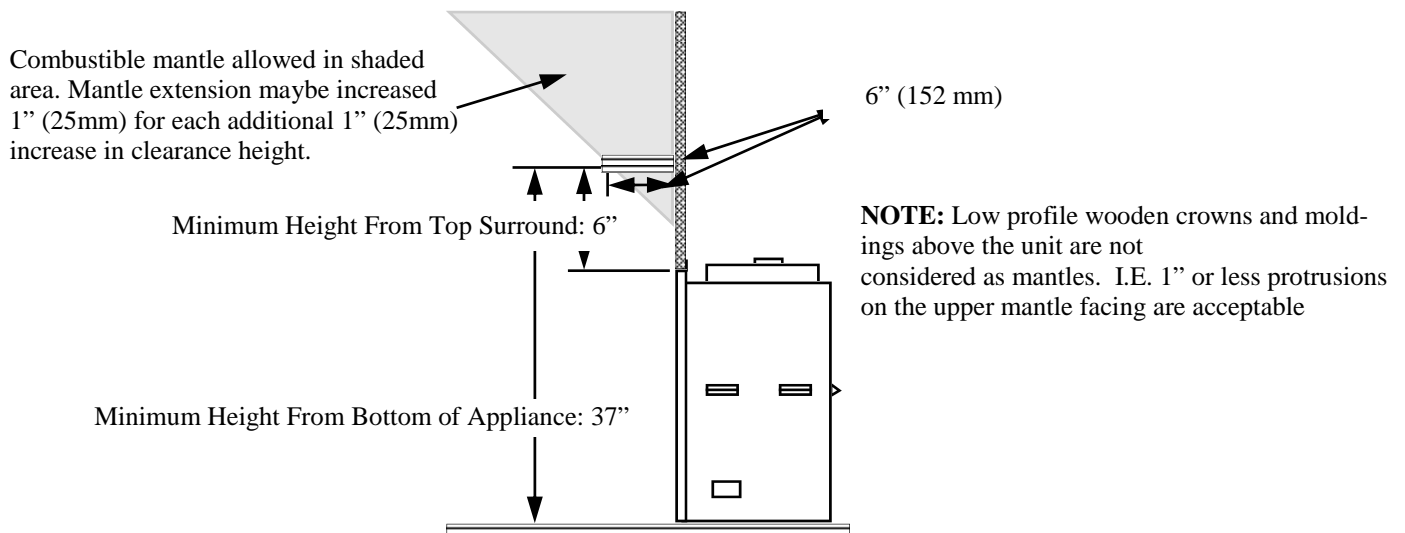

POSSIBLE FIREPLACE LOCATIONS

LOCATING GAS FIREPLACE

This appliance must be installed in any location that is free of plumbing, electrical wiring and heating or air conditioning ducts. Select a location that is accessible for venting. See PAGE “ALLOWABLE TERMINATION LOCATIONS”.

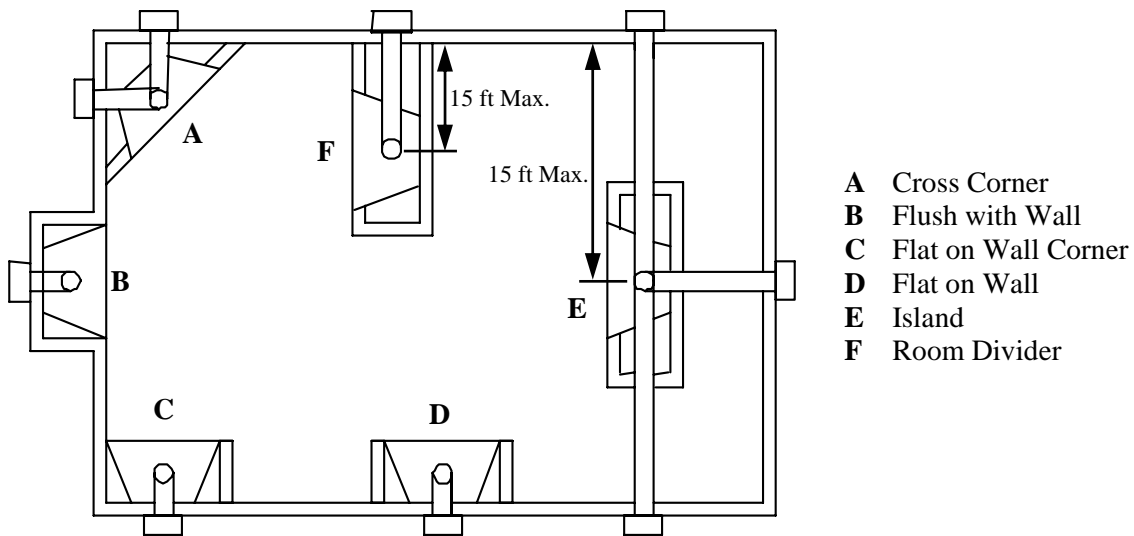

***NOTE: Rear vented gas fireplace DV-38 can only be located in positions A, B, C and D.**

**REFER TO THE VENTING SELECTION OF THIS MANUAL FOR
ALLOWABLE VENTING CONFIGURATIONS**

VENTING INSTRUCTIONS

VENT TERMINATION

1. See “ALLOWABLE TERMINATION LOCATIONS” diagram (page 13) to establish a suitable vent termination location.
2. In heavy snowfall areas make sure vent termination is located where it can not be blocked by snow from snow removal equipment.
3. Locate vent termination away from plants, bushes or any other object on or near the vent termination that will interfere or obstruct the air flow around it.
4. DO NOT recess vent termination into walls, sidings or planters.
5. Vent terminations located below 7ft from grade level or anywhere it can be a burn hazard to the public, such as patios and balconies, must be protected with an Archgard approved termination cage.
6. Always ensure bottom of Vent Terminal is a minimum of 12” above grade.

VENTING

The appliance will not function without being connected to a proper venting system.

This appliance may use 4” and 7” gas flex vents with DV-38 listed vent components, or Simpson Dura-vent 4 x 6-5/8 direct vent systems with Simpson Dura-vent Adaptor (SDA-3). 7” dia. rigid vent may directly replace 7” dia. flex vent in all applications.

For best venting performance using gas flex vent, here are some general venting rules that we recommend:

1. Use only 4” and 7” diameter 2-ply certified gas flex vent in a co-axial configuration.
2. Maintain a minimum clearance of 1” to the sides and bottom and 2” to the top outside surface of the vent pipe and combustible material.
3. Observe any local code restrictions, if any, regarding the installation of this type of gas appliance.
4. Observe the venting chart given in this manual.
5. Use a vent spacer between the inside and outside flex vents at every 3 ft intervals.
6. Never slope horizontal running vents downwards.
7. **VERY IMPORTANT: Maintain at least an upward slope of 1” for every 1 ft of horizontal run on the rear vented models.**
8. Terminate the vent with a vent termination supplied by Archgard Industries Ltd.
9. Support horizontal running vents every 3 ft to prevent it from sagging.
10. Wall terminal must be installed a minimum of 12” above grade measured from bottom of terminal.

VENTING INSTRUCTIONS Cont...

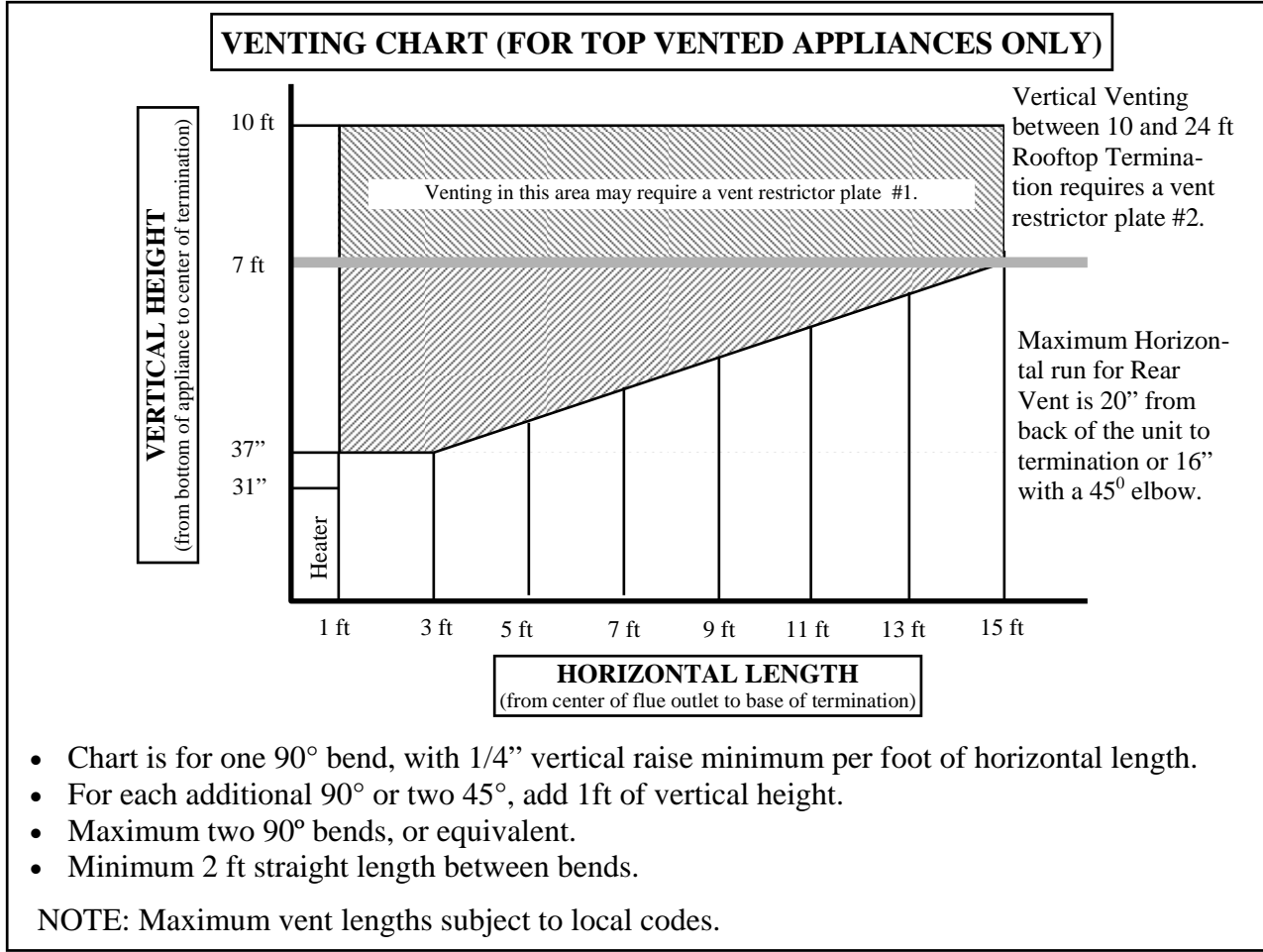

Maintain a minimum of 1" clearance to combustibles on sides and bottom and 2" from top surface of the vent.

The gas fireplace is designed and optimized for majority of the installations with short vents. With taller vents the flame characteristics will change.

VERTICAL VENTING (THROUGH THE ROOF) FOR ROOFTOP VENTED APPLIANCES

- Use only Simpson Dura-Vent 4 x 6-5/8" direct vent systems and Simpson Dura-Vent venting components.
- Maximum vertical height of 24 feet.
- Vertical height of the vent system must have at least 3 ft or more per 90° elbow in the vent system.
- Vertical height of the vent system must also be increased 1 ft for every 2 ft of horizontal length added to the vent system.

Example: A vertical venting system with a 90° elbow, a horizontal offset of 4 ft and another 90° elbow. Vertical vent height of the vent system must be 3ft + 2ft + 3ft = 8 ft or higher to a maximum of 24 feet.

VENTING INSTRUCTIONS Cont...

RESTRICTOR PLACEMENT “FOR ABOVE 7 FOOT VERTICAL RISE VENTED APPLICATIONS ONLY”

WARNING: These restrictors are only to be installed in the vent system if the vent exceeds 7’ in vertical height, *Restrictor Number 1 below is required. **Installing them under any other circumstances may cause hazardous venting conditions and may result in personal injury, property damage or death.**

“NOT FOR USE IN SIDEWALL VENTED APPLICATIONS”



Restrictor #1



Restrictor #2

Vertical Venting Between Seven Feet (7’) and Ten Feet (10’) must use Restrictor # 1. Vertical Venting Between Ten Feet (10’) and Twenty-four Feet (24’) for Rooftop Terminations must use Restrictor #2 . See Venting Chart on page 10.

NOTE: Vent restrictors are designed to reduce vertical stack action for above 7 feet, which will reduce the velocity of incoming combustion air and not adversely affect the standing pilot or the flame of the appliance.

Archgard System

In the Archgard system the restrictors are placed on the exhaust outlet on the appliance.

Simpson Duravent

With Simpson Duravent locate the restrictor in the exhaust section fitting into the formed lip.

Simpson Duravent



Archgard System



Restrictor Placement

VENTING INSTRUCTIONS Cont...

ALLOWABLE TERMINATION LOCATIONS.

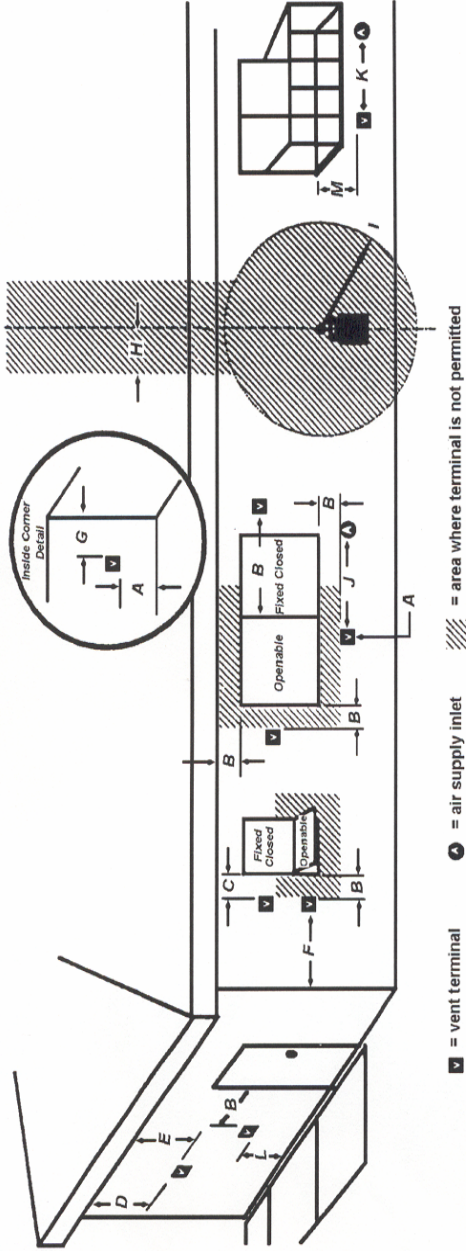

	Canadian Installations (1)	US Installations (2)	Canadian Installations (1)	US Installations (2)
A= Clearance above grade, veranda, porch, deck, or balcony	12 inches (30 cm)	12 inches (30 cm)	J= Clearance to non-mechanical air supply inlet to building or the combustion air inlet or any other appliance	9 inches (23 cm)
B= Clearance to window or door that may be opened	12 inches (30 cm)	12 inches (30 cm)	K= Clearance to a mechanical air supply inlet	3 feet (91 cm) above if within 10 feet (3 m) horizontally
C= Clearance to permanently closed window	*	*	L= Clearance above paved sidewalk or paved driveway located on public property	7 feet (2.13 m) +
D= Vertical clearance to ventilated soffit located above the terminal within a horizontal distance of 2 feet (61 cm) from the center line of the terminal	*	*	M= Clearance under veranda, porch, deck, or balcony	*
E= Clearance to unventilated soffit	*	*		
F= Clearance to outside corner	*	*		
G= Clearance to inside corner	*	*		
H= Clearance to each side of center line extended above meter/regulator assembly	3 feet (91 cm) within a height 15 feet (4.5 m) above the meter/regulator assembly	*		
L= Clearance to service regulator vent outlet	3 feet (91 cm)	*		

(1) In accordance with the current CSA B149.1, *National Gas and Propane Installation Code*
 (2) In accordance with the current ANSI Z223.1/NFPA 54, *National Fuel Gas Code*
 (+) A vent shall not terminate directly above a side walk or paved driveway that is located between two single family dwellings and serves both dwellings
 (++) Permitted only if veranda, porch, deck, or balcony is fully open on a minimum of two sides beneath the floor.
 (*) For clearances not specified in ANSI Z223.1/NFPA 54 or CSA B149.1, "Clearances shall be in accordance with local installation codes and the requirements of the gas supplier."

GAS CONNECTIONS

Please follow the venting instructions as strictly as possible to obtain the best performance from the appliance.

GAS CONNECTIONS

Before connecting the appliance to the gas supply line, double check that the appliance you have purchased is designed for the gas type you are using. The gas type markings are located on the certification label and also on the appliance's gas valve.

Provide adequate clearance for proper installation and checking of the gas connections.

Have your gas supplier or a qualified gas fitter run a gas supply line into the gas fireplace. The line must be properly sized and fitted according to the installation codes. Up stream of the appliance supply connection, the fitter shall provide an easily accessible manual shut-off valve.

CAUTION: The appliance and its individual shutoff valve must be disconnected from the gas supply piping system during any pressure testing of that system at test pressures in excess of 1/2 psig (3.5 kPa). The appliance must be isolated from the gas supply piping system by closing its individual manual shutoff valve during any pressure testing of the gas supply piping system at test pressures equal to or less than 1/2 psig (3.5 kPa). Failure to do so will damage the appliance's gas valve. Such damage is not covered by the manufacturer's warranty.

Check for proper gas supply pressure by loosening the set screw on the supply pressure tap (marked **IN**) on the gas valve with a small flat tip screw driver and placing a test gauge on the tap.

The minimum permissible gas supply pressure is 4.5 in. w.c. (1.12 kPa) for natural gas and 11.0 in. w.c. (2.74 kPa) for propane. Maximum gas supply pressure should never exceed 14.0 in. w.c. (3.48 kPa) or 1/2 psi. for both natural gas and propane.

BE SURE TO TIGHTEN THE PRESSURE TAP SET SCREW AFTER CHECKING THE PRESSURE. CHECK ALL GAS CONNECTIONS FOR GAS LEAKS.

GLASS DOOR INSTRUCTIONS

GLASS DOOR

WARNING: Do not attempt to remove the glass door when the appliance is hot.

Removing the Glass Door

Remove the top and bottom louvers.

There are two latches under the firebox. Undo the latches, swing the bottom of the door away from the appliance and then lift the door off the top retaining tabs. Carefully place the door in a safe location where it cannot be scratched or damaged.

Replacing the Glass Door

The reverse procedure of Removing the Glass Door.

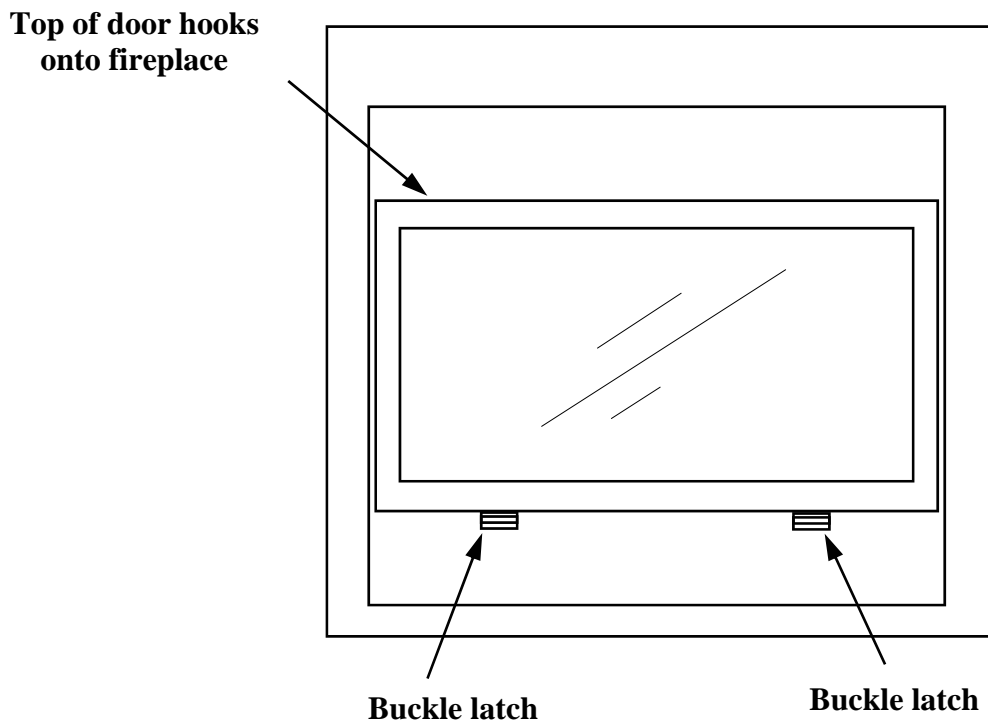

LOG PLACEMENT INSTRUCTIONS

PLACEMENT OF LOGSET, FIBER COALS & EMBER WOOL

- Place the back log at the back of the burner tray as shown, behind the two tabs on the burner tray.
- Place the front log on top of the burner as shown. The metal tabs protruding from the bottom of the log straddle the side of the burner top.
- Place the branches directly on the front and back logs as shown. There are locating holes on the bottom of the branches to mate with metal pins protruding from the top of the front log.
- A bag of fiber coals and a bag of ember wool is provided with the heater.
- Place the fiber coals on the burner tray, surrounding the burner. **DO NOT** place fiber coals on the burner itself.
- Tear ember wool into 1/2" to 3/4" diameter ember pieces and place them on the edges of the burner so as to hide the transition between the fiber coals and the burner. Keep the embers from obstructing the burner ports.

Do not add any materials to the burner, other than the type and amount provided by Archgard.

LOG SETUP DETAIL

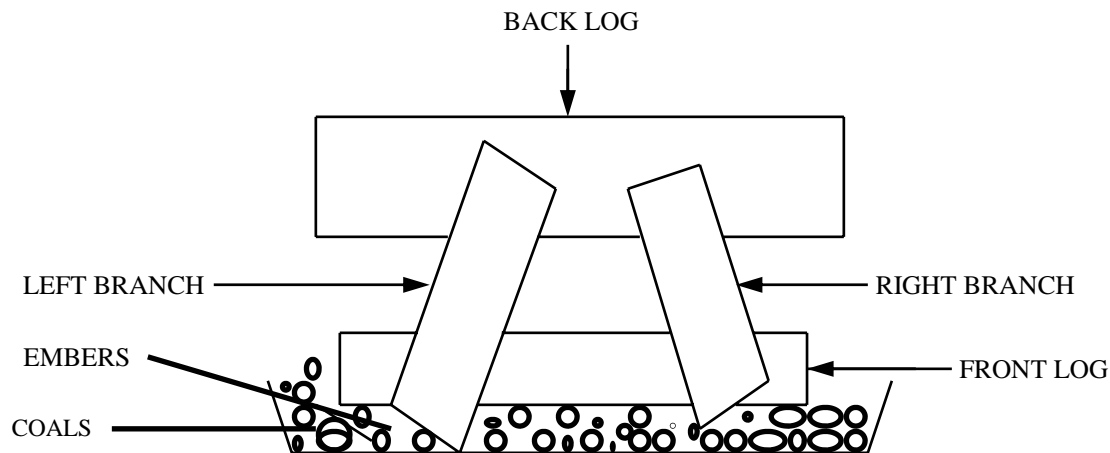

WARNING : Do not place the logs and branches in any configuration other than the one shown, a fire, explosion or excessive carbon monoxide (CO) may result, causing property damage, personal injury or loss of life.

FAN & VALVE WIRING DIAGRAM/INSTRUCTIONS

ELECTRICAL CONNECTIONS (for optional convection fan kit FK 36/38 only)

- Install the fan first. Remove the lower louvers and gently place the bottom front lip of the blower mounting bracket into the opening. Slide the blower assembly into the bottom of the fireplace. Rotate the blower into position. Be careful not to damage the fan blades. The fan blades will now face towards you. Line up the holes on fan bracket to the mounting bracket at the bottom of the fireplace. Place a screw at each of the three holes and tighten.
- Run 120VAC power line through the left side of the fireplace and into the bottom of the gas fireplace.
- Be sure to connect a grounding wire to the side of gas fireplace. Use any screw hole on the side for this purpose.
- Slide the thermal snap switch into the fork like bracket underneath the left side of the firebox.
- Neatly tie down and tuck the wires down at the bottom and to the back of the fireplace.
- **CAUTION:** Do not allow any wires to touch the bottom of the firebox. Otherwise, the wires will melt and short-out.
- Screw the speed controller bracket to the bottom left sidewall of the gas fireplace.

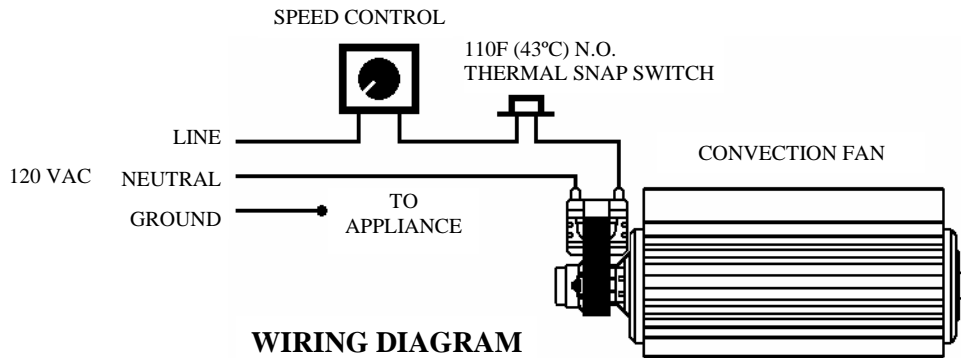

VALVE CONNECTIONS

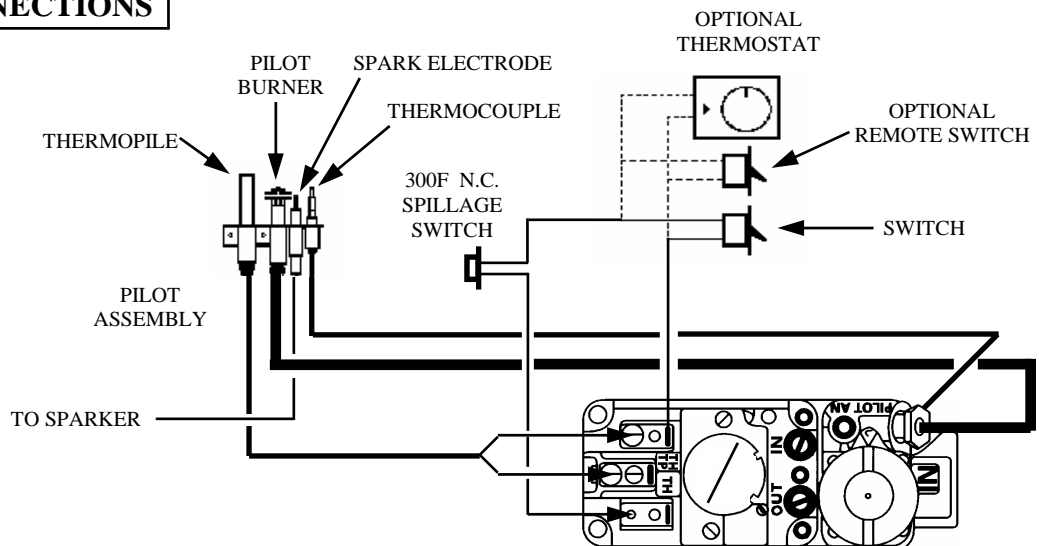

INITIAL START UP INSTRUCTIONS**FOR YOUR SAFETY, READ BEFORE LIGHTING****INITIAL OPERATION**

- Check that the appliance is properly vented and connected to the gas supply.
- Check that the logs and branches are properly placed.
- Check all external parts, such as grills, door and control cover are properly attached and fastened.
- Check to ensure the pressure relief door on top of the firebox and behind the upper louvers is closed and properly sealed on the gasket.

NOTE : When operated for the first few times, the appliance will emit some odors and fumes. This is due to the evaporation of oils and solvents used in fabricating the appliance. Close off the room to the rest of the house and open all windows. Keep the room well ventilated. Operate the appliance continuously on high setting for at least 4 to 6 hours. This will 'burn-in' the appliance and reduce the chance of odors and fumes reoccurring the next time the appliance is used.

WARNING : If you do not follow these instructions exactly, a fire or explosion may result, causing property damage, personal injury or loss of life.

- A.** This appliance has a pilot which must be lit by hand using the sparker located next to the appliance valve controls. When lighting the pilot, follow the start-up procedures exactly.
- B.** BEFORE LIGHTING, smell all around the appliance area for gas. Be sure to smell next to the floor, because some gases are heavier than air and will settle on the floor. IF YOU SMELL GAS, follow the instruction on the front cover of this manual.
- C.** Use only your hand to push in or turn the gas control knob. Never use tools. If the knob will not push in or turn by hand, do not try to repair it. Call a qualified service technician. Force or attempted repair may result in a fire or explosion.
- D.** Do not use this appliance if any part has been under water. Immediately call a qualified service technician to inspect the appliance and to replace any part of the control system and any gas control which has been under water.

INITIAL START UP INSTRUCTIONS Cont..**START-UP PROCEDURE**

1. Set the thermostat, if present, to the lowest level. Press slightly and turn the control knob clockwise ↻ to the **OFF** position and wait 5 minutes; thus allowing any gases to escape which may have accumulated in the combustion chamber.
Note: LP gases do not vent upward. Then follow step 2 and 3 to establish pilot.
2. Press slightly and turn control knob counterclockwise ↺ to **PILOT** position; depress control knob and light pilot by repeatedly pressing the sparker. Venting of air may take place at the pilot prior to the flow of fuel gases. Once flame is established, hold knob depressed for approximately 60 sec.
3. Release control knob. If pilot should go out, turn the control knob to **OFF** position and repeat steps 1, 2 and 3.
Note: this will allow reset of INTERLOCK for proper lighting of pilot.
4. Press and turn control knob counterclockwise ↺ to **ON** position.
5. Turn thermostat to the desired comfort level or turn ON/OFF switch to the ON position.

TEMPORARY SHUT-DOWN PROCEDURE

6. To turn off the main burner only, set the thermostat to the lowest setting or turn remote switch to **OFF**. Press and turn the control knob clockwise ↻ to **PILOT** position.

COMPLETE SHUT-DOWN PROCEDURE

7. Press and turn the control knob clockwise ↻ to the **OFF** position.

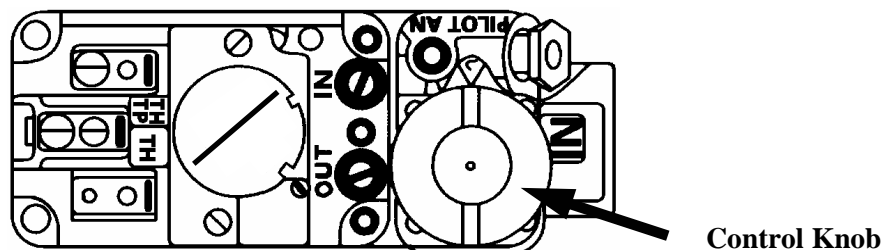

MAINTENANCE

CAUTION : Only conduct maintenance on a cold appliance.

CLEANING THE APPLIANCE

The exterior painted surfaces, glass and gold trims may be cleaned with a soft, non-abrasive cloth and water or a suitable, mild, non-abrasive cleaner.

Regularly,

- Clean and remove any lint accumulations or debris from the grills and in any combustion and convection air passage ways.
- Keep the appliance area free from combustible materials, such as paper, wood, clothing, gasoline and flammable solids, liquids and vapors.
- Visually check the height and color of the burner and pilot flames.
- Check for unusual noise, odor and operation of the appliance.
- Check the vent terminal for any damage, or obstruction by plants or debris accumulation.

Once a Year,

- Remove the glass door and clean the inside of the glass with a soft, non-abrasive cloth and water or a suitable, mild, non-abrasive cleaner.
- Carefully remove the logs and gently brush off any loose carbon deposits. This job is best done outside the house, wearing a dust mask. The logs are very fragile, take care not to break them. After cleaning, the logs must be replaced as per the instructions in this manual.
- When replacing glass door, ensure the gasket is still secure all around the edge of the glass and it is sealing against the firebox frame. Replace the gasket is worn, damaged or falling off.

Once a Year have a qualified service technician,

- Completely inspect the appliance and the venting system.
- Clean and remove any lint accumulations or debris in the firebox, on the burners, on the pilot, at the primary air opening, on the optional convection air blower and in any combustion and convection air passage ways.
- Check the safety system of the gas valve.
- Check condition of both glass door gasket and top pressure relief door gasket. Replace if damaged or worn.

WARNING : All parts removed or disturbed must be properly replaced after maintenance. Service and repair must be conducted by a qualified service person. If these instructions are not followed, a fire or explosion may result, causing property damage, personal injury or loss of life

TROUBLESHOOTING

Please check to make sure the instructions are followed exactly before attempting troubleshooting of the appliance.

WARNING: Troubleshooting and servicing of gas and electrical devices of the appliance should only be conducted by a qualified service technician.

SYMPTOM	ACTION
Pilot will not light after pressing the sparker many times.	<ol style="list-style-type: none"> 1. When lighting the appliance for the first time after installation or after servicing, there is air in the gas line. It takes a while for all the air to purge out of the pilot before gas can reach the pilot and ignite. Remove the glass door and try lighting the pilot many times to purge the air. 2. Check to make sure the gas supply to the appliance is turned on and there is adequate gas supply pressure to the appliance. 3. Check for sparks between the spark electrode and the pilot head when the sparker is pressed. If there are no sparks, <ol style="list-style-type: none"> a. Check for broken or poor connection from the sparker to the electrode. b. Check for the spark shorting or arcing at other locations. c. Check for defective sparker. d. Check for defective spark electrode. 4. With the door removed, try lighting the pilot with a match. <ol style="list-style-type: none"> a. If air is blowing on the flame of the match, hold the control knob in at the 'PILOT' setting until all the air is purged out of the line. b. If there is no gas or air coming out of the pilot and there is gas pressure to the appliance, the pilot orifice may be blocked or the gas valve may be defective.
Pilot will not remain on after being lit.	<ol style="list-style-type: none"> 1. Press the control knob all the way in. 2. Hold the control knob in for a longer period of time. 3. If you are trying to re-light the pilot immediately after you have shut-off the pilot, you have to wait a few minutes for the valve to reset. 4. Check to see if the pilot flame is large enough to reach and surround the thermocouple. If the flame is too small, check for correct gas supply pressure. If pressure is good, adjust the pilot flame size with the adjustment screw on the valve. If the flame cannot be adjusted, there might be some debris obstructing the pilot orifice. 5. Check for poor connection of the thermocouple to the valve. 6. Check for proper millivolts of the thermocouple. The thermocouple should generate at least 30 mV or it is defective. 7. Check for defective gas valve.
The main burner does not turn on with the pilot lit.	<ol style="list-style-type: none"> 1. Check to make sure the control knob is turned to the 'ON' position. 2. The thermopile takes a bit of time to heat up and generate enough voltage to activate the valve. Wait a little longer.

TROUBLE SHOOTING Cont...

SYMPTOM	ACTION
The main burner does not turn on with the pilot lit. Cont...	<ol style="list-style-type: none"> 3. Check to make sure the thermostat is set high enough to turn on the appliance. 4. Check that the remote switch or the thermostat is turned on. 5. Check for weak pilot flame. If flame is weak, check gas supply, check pilot flame adjustment and check for blockage of pilot orifice. 6. Check for 400-500 mV from the thermopile with the burner off and 200-250 mV with the burner on. If the voltages are lower, the thermopile is defective. 7. Check for defective gas valve.
The main burner shuts off when the appliance is warm.	<ol style="list-style-type: none"> 1. This may be the normal operation of a wall thermostat installed to appliances. 2. Check for good pilot flames on the thermopile. 3. Check for good voltage from the thermopile.
Sooty deposits on the glass door.	<ol style="list-style-type: none"> 1. If the flame is yellow and lazy, increase primary air by opening the primary air shutter. 2. Check for proper placement of the logs and branches. See that section in the instruction manual. 3. Check for obstruction of the burner ports by the embers. See that section in the instruction manual. 4. Check for proper venting and blockage of the vent termination. 5. Check manifold pressure and clock input rating.
Sharp blue flames with flames lifting off the burner at the ends.	<ol style="list-style-type: none"> 1. Too much primary air. Reduce primary air by closing the primary air shutter. During cold temperatures, some flame lifting may occur during start-up.
Convection blower does not turn on.	<ol style="list-style-type: none"> 1. The convection fan is thermostatically controlled. It will only turn on when the appliance is warmed-up. This may take 5 to 15 minutes with the appliance on high. 2. Check for 120VAC electrical supply to the appliance. 3. Check for proper mounting of the thermal snap disc. 4. Check electrical connections. 5. Check for defective thermal snap disc. 6. Check for defective convection blower speed controller. 7. Check for defective convection blower.

SERVICING

WARNING: Servicing of this appliance must be conducted by a qualified service technician. Improper servicing, adjustment or alteration of this appliance may cause property damage, personal injury or loss of life. All servicing should be conducted with the appliance cold.

SERVICING UNDER WARRANTY

Before servicing, read the terms and conditions of the Archgard warranty at the back of the manual. Contact the Archgard authorized dealer where you purchased the appliance and provide them with details of the problem and the installation information which the installer filled out at the back of the manual.

ADJUSTING PRIMARY AIR

The Shutter is set at the factory and normally only requires setting at higher altitudes.

WARNING: Any Adjustment to Primary Air Should Be Attempted by a Qualified Licensed Gas Fitter or Service Person.

- Remove the glass door.
- The primary air shutter is located underneath the burner.
- See page 3 or rating plate for shutter adjustment.
- Loosen the air shutter screw with a Philips ('+') screwdriver.
- Rotate air shutter with a flat tip screw driver. The primary air opening size can be easily seen with a flashlight.
- Tighten the air shutter screw after adjustment.
- Caution: Wear gloves when adjusting the primary air when the appliance is HOT.

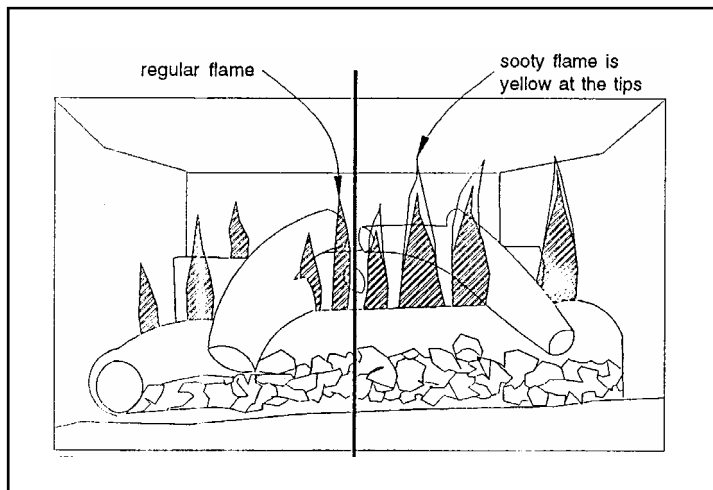

FLAMES... (Reference only)

The left side shows correct adjustment. The right side shows yellow sooty flames requiring increase in shutter opening or cleaning of shutter area due to lint buildup.

SERVICING Cont...

CHANGING MAIN BURNER ORIFICE

- Remove the glass door, log set and the burner.
- Use a 5/8" wrench to loosen the compression fitting to the cap orifice.
- Use two 1/2" wrenches to loosen and remove the cap orifice.
- Change the orifice.
- Replace the compression fitting.
- Replace the burner and the log set.
- Test fire the appliance with the glass door off and check for gas leaks.
- Replace the glass door.

CHECKING INLET AND OUTLET GAS PRESSURE

- Remove the bottom grill.
- The pressure test taps are located on front of the valve.
- The supply pressure is marked 'IN' and the manifold pressure is marked 'OUT'. There is also an arrow marking the direction of gas flow.
- Loosen the screw inside the tap with a 1/8" wide flat screw driver.
- Connect a 1/4" rubber tube to the tap and a pressure gauge.
- **Be sure to tighten the screw inside the tap after you are finished taking pressure readings.**

CHECKING AND ADJUSTING PILOT

The pilot flame should have the characteristic as shown in the illustration below. The flame should not have yellow tips but should engulf the thermocouple and thermopile. It can be adjusted by turning the screw marked "pilot" on the control valve.

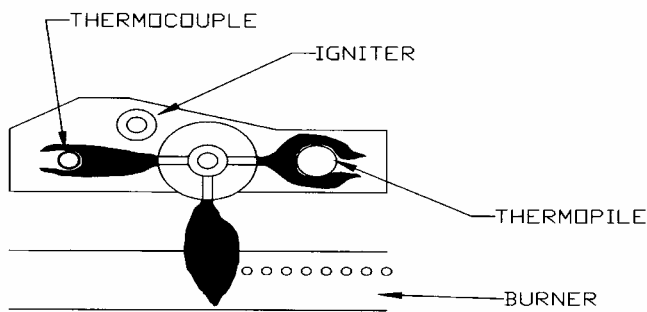

REFERENCE ONLY

SERVICING Cont...**CONVERTIBLE PILOT ORIFICE**

The pilot assembly is convertible to the type of gas being used, simply unscrew the body by using a 7/16" (11 mm) wrench turn a 1/4 open then push the small metal tab across to the other side of the body and retighten. **Call your local Authorized Archgard Dealer to purchase the correct fuel conversion kit for your gas appliance.**

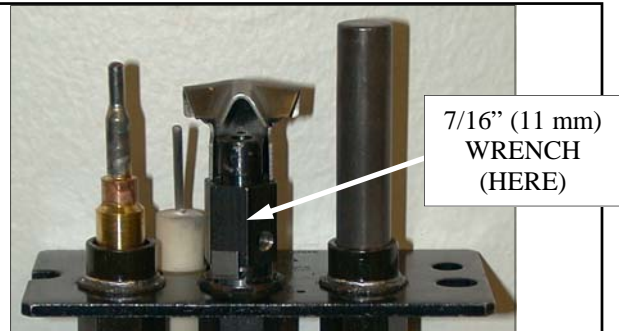
**IF YOUR GLASS BREAKS**

In the event your glass cracks or breaks, it must be replaced by the exact same size and material. It is made from high temperature ceramic material. See replacement parts list and contact your nearest Archgard dealer.

- Remove door and carefully remove all traces of glass and gasket material. See page 14 for glass door removal.
- Clean glass fame & ensure no "old" gasket or glue remains.
- Install new glass and gasket. The "thicker" side of the gasket fits against the fireplace opening.
- Hold glass in place by using the sealer between gasket and door. Use sparingly so that no excess will be visible. **DO NOT PUT ANY SEALER BETWEEN GLASS AND UNIT OPENING.**
- Replace the door carefully making sure both clamps are closed.

SERVICING Cont...

REPLACING VALVE PLATE ASSEMBLY

Replacing Gas Component Assembly

- Disconnect electricity to the appliance. (If equipped with Optional Fan Kit)
- Remove the glass door and the logs. (See installation section pages 11 and 12)
- Remove the burner tray by loosening and removing the two mounting screws located on the sides of the burner.
-
- Shut off the gas to the appliance and disconnect the gas line to the appliance.
- If the appliance has a remote switch or thermostat, disconnect their wires at the front of the valve.
- Remove the four screws holding the gas component assembly plate to the appliance.
- Gently lift the assembly up and tilt the back up to clear the front of the valve from the opening.
- Replacing the assembly is the reverse of the above instructions.

REPLACING OPTIONAL CONVECTION BLOWER

- Disconnect power to the gas fireplace.
- Remove the fan speed mounting bracket.
- The convection blower is located at the bottom of the appliance at the back. Remove the three screws holding the blower.
- Rotate the blower to the left and carefully take the blower out with its back end out first.
- Disconnect the wires from the blower.

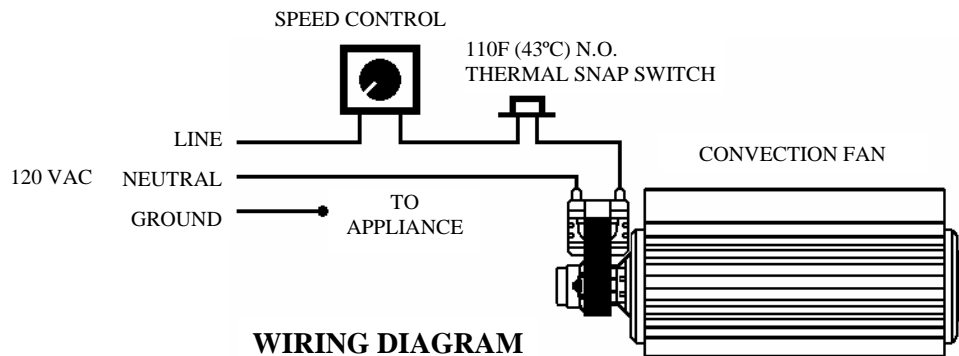



Replacement Parts list for Marquis DV-38D & DVT38D

Item #	Item Description	Qty	Unit
200-0044	OWNER'S MANUAL, MARQUIS DV-38D & DVT38D	1	EA
301-0068	ORIFICE CAP, DRILL TO #56 (PROPANE GAS)	1	EA
301-0068	ORIFICE CAP, DRILL TO #48 (NATURAL GAS)	1	EA
305-0013	FAN SPEED CONTROL (RHEOSTAT) FOR OPTIONAL FAN KIT FK-36/38	1	EA
305-0021	FAN THERMODISK 110 DEG. FOR OPTIONAL FAN KIT FK-36/38	1	EA
305-0024	FAN, CROSSFLOW 110 CFM FOR OPTIONAL FAN KIT FK-36/38	1	EA
307-0000	GLASS 5MM TEMP BRONZE 17.25X30.50	1	EA
308-0007	PIEZO IGNITOR FOR MOUNTING ON SIT VALVE	1	EA
308-0065	VALVE NOVA SIT NO TURNDOWN (NATURAL GAS)	1	EA
308-0085	VALVE NOVA SIT NO TURNDOWN (PROPANE)	1	EA
308-0093	PILOT ASSEMBLY, PSE TOP MOUNT CONVERTIBLE NG/LP	1	EA
308-0009	COALS. MEDIUM GRADE 4OZ BAG	1	EA
308-0056	THERMOPILE ONLY	1	EA
308-0057	THERMOCOUPLE ONLY	1	EA
310-0035	LOG, FRONT	1	EA
310-0036	LOG, REAR	1	EA
310-0037	LOG (S) LEFT & RIGHT	2	EA
310-0046	MINERAL WOOL "EMBERS"	1	OZ
314-0000	GASKET GF , TADPOLE 1.38" (GLASS GASKET)	1	EA
311-0028	BRICK LINER RIGHT HAND FOR OPTIONAL BRPL-36	1	EA
311-0029	BRICK LINER, LEFT HAND FOR OPTIONAL BRPL-36	1	EA
311-0030	BRICK LINER, REAR FOR OPTIONAL BRPL-36	1	EA
838-0050	BURNER ASSEMBLY NATURAL GAS ONLY	1	EA
838-0051	BURNER ASSEMBLY PROPANE ONLY	1	EA

Parts can be ordered through your local dealer or distributor by giving ITEM # and DESCRIPTION.

ARCHGARD LIMITED WARRANTY

This Limited Warranty is made by ARCHGARD INDUSTRIES LTD., hereinafter referred to as "Archgard". Archgard warrants to the original purchaser of an Archgard gas burning fireplace(s) that the product will be free from defects in materials and workmanship under normal use and service, for a "lifetime".

INCLUSIONS: "LIFETIME LIMITED WARRANTY"

- * All heat exchangers, combustion chamber, burner tubes and pans
- * Ceramic Fiber Logs and Ceramic Brick Panels, against splitting and cracking
- * Ceramic Glass against thermal breakage
- * All 24K gold trims and accessories against tarnishing
- * All trim accessories against tarnishing and paint defects

NOTE: discoloration and some minor movement of certain parts are normal and are not a defect; therefore, not covered under warranty.

The above will be covered under "Parts & Labour" to the original purchaser for five (5) years and "Parts Only" thereafter from original date of purchase.

INCLUSIONS: "FIVE YEAR LIMITED WARRANTY"

- * "FiberFlame Technology Burner System" – any defective burner and ceramic ember bed if defect is deemed as original by the manufacturer.

The above will be covered under "Parts & Labour" to the original purchaser for two (2) years and "Parts Only" thereafter from original date of purchase.

INCLUSIONS: "ONE YEAR LIMITED WARRANTY"

- * Blowers, fans and fan motors, wiring, rheostats and thermodiscs
- * Rocker switches, spill switches and wiring to them
- * Gas control valves, pilot assemblies including thermopiles, thermocouples, electrodes and igniters

The above will be covered under "Parts & Labour" to the original purchaser for one (1) year from date of purchase.

EXCLUSIONS:

- * Archgard does not offer wall-mounted thermostats, programmable thermostats (wiring for hook-up of said product), handheld remote controls, fireplace mantles, trims or tiles.
- * Tempered Glass is under warranty for ONE year to the original purchaser from date of purchase
- * Travel time or mileage to original purchaser's residence. Archgard suggests that you pre-arrange travel expenses with your Authorized Archgard Dealer.

WHAT TO DO IN THE EVENT OF A PROBLEM:

- * Thoroughly read your "Owner's Installation, Operation & Maintenance Manual"
- * If you cannot solve the problem, contact your Archgard dealer or representative
- * When calling for assistance, please have the following information:

Model of your fireplace	Serial Number	Place of Purchase
Date of Purchase	Problem Description	

NOTE: Warranty may be void if work is carried out by an unqualified person(s). Only original Archgard parts may be used. Please consult you Archgard dealer or representative if in doubt about a replacement part(s).

OBTAINING WARRANTY SERVICE:

The original purchaser shall return the defective part(s) to the original authorized Archgard dealer – transaction prepaid, along with the serial number of the appliance and original proof of purchase. Any defective part, in our judgment, will be repaired or replaced at Archgard's discretion. The dealer must obtain approval from Archgard before any repairs are made.

WARRANTY LIMITATION:

THIS LIMITED WARRANTY IS MADE IN LIEU OF ALL OTHER WARRANTIES, EXPRESSED OR IMPLIED AS TO QUALITY, MERCHANTABILITY OR FITNESS FOR PARTICULAR PURPOSE.

The appliance is only warranted for the use as intended by the installation and operating instructions and local building codes. The warranty will not cover damage due to accident, misuse, abuse, alteration, improper installation or "Acts of God". This limited warranty is void unless the appliance is installed by a qualified installer, in accordance with the instructions furnished with the appliance. Some Provinces or States do not allow limitations on how long an implied warranty lasts, so the above limitations may not apply to the original purchaser. Any damage resulting from defects in this product is limited to the replacement of the defective part(s) and does not include incidental and consequential exposures sustained in connection with the product. This includes facing(s), mantle(s), cabinet(s), tile(s) or any other finishes resulting from removal of any gas appliance. This warranty is limited to residential use only and gives the consumer specific rights. These rights may vary from State to State or Province to Province.

Postage

WARRANTY REGISTRATION

**ARCHGARD INDUSTRIES LTD.
7116 BEATTY DRIVE
MISSION, B.C. CANADA
V2V 6B4**

CUT ALONG LINE

FOLD DOWN AT LINE

CUT ALONG LINE

FOLD DOWN AT LINE & TAPE CLOSED

Model # : _____ Serial #: _____ Date Installed: _____ / _____ / _____

Name & Address: _____

City: _____ State/Prov: _____ Phone: (_____) _____

Dealer's Name & Address: _____

City: _____ State/Prov: _____ Phone: (_____) _____

Installer's Name & Address: _____

City: _____ State/Prov: _____ Phone: (_____) _____

Why did you choose this product? _____

CUT ALONG LINE

Thank you for purchasing our product and filling out this warranty card.

Archgard Industries Ltd.
7116 Beatty Drive
Mission, British Columbia, Canada
V2V 6B4
Telephone: 604-820-8262
Telephone Toll Free: 877-820-9800
Fax: 604-820-8881
Fax Toll Free: 866-820-2802
Website: www.archgard.com